

Paper copy of “Appendix: Property Tables and Charts” and a collection of mathematical formulas on a sheet of A4 are allowed to the exam. **Note!** Return the question paper with your answers.

1. Define the following terms in your own words:
 - (a) relative humidity (suom. *suhteellinen kosteus*)
 - (b) absolute humidity (suom. *absoluuttinen kosteus*)
 - (c) simple Rankine cycle (suom. *yksinkertainen Rankine-prosessi*)
 - (d) saturated air (suom. *kyllästetty ilma*)

2. An actual vapor-compression refrigeration cycle differs from the ideal one in several ways, owing mostly to the irreversibilities that occur in various components. Disregarding any heat transfer and pressure drops in the connecting lines between the components:
 - (a) Give the reasons for the entropy increase or decrease during a compression process in the actual cycle.
 - (b) Does the ideal vapor-compression refrigeration cycle involve any internal irreversibilities? Explain.
 - (c) Show the p - h diagrams for the ideal and the actual vapor-compression cycles, respectively, relative to saturation lines.

3. The Atkinson cycle is executed in a closed system (Figure 1). The cycle consists of isentropic compression, constant volume heat addition, isentropic expansion, and constant pressure compression. On cold air-standard basis, derive an expression for the thermal efficiency of the cycle in terms of the volume ratio during the isentropic compression ($r = v_1/v_2$), the pressure ratio for the constant volume process ($r_p = p_3/p_2$), and the specific heat ratio ($k = c_p/c_v$).

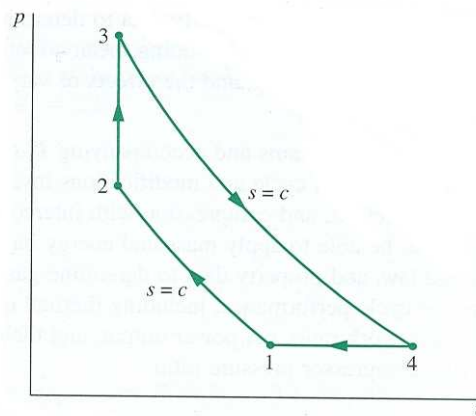
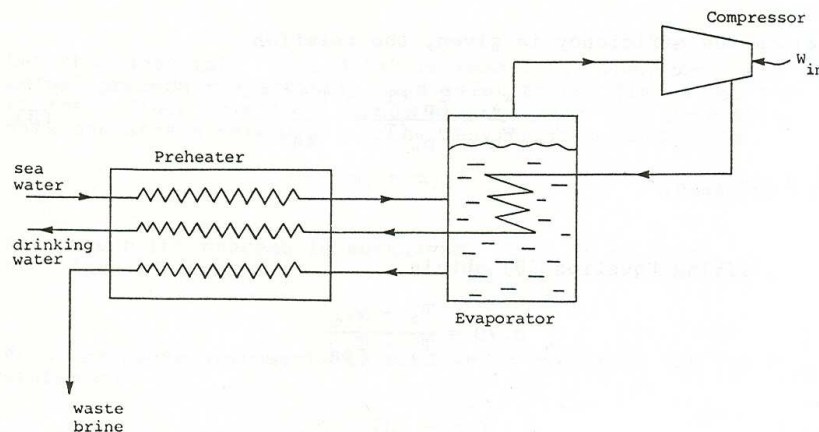

Figure 1. The pressure-specific volume diagram of the air-standard Atkinson cycle

4. The unit shown below is used to produce drinking water from sea water by a vapor-compression desalination process. Seawater (3,5% salt) enters the unit and is pre-heated by countercurrent contact with the drinking water and the waste brine (suom. *suolavesi*). The preheated seawater then enters the evaporator at 1 atm, where a portion is boiled off by condensing steam. The boiled water leaves the evaporator as steam at 105°C and is compressed adiabatically to 1,5 bar, and is then cooled to produce the drinking water. If the compressor has an isentropic efficiency of 60%, calculate the temperature at the outlet of the compressor and the work of compression per kilogram of drinking water formed.



5. Name the following power cycles that are shown here on both T - s and p - v diagrams. (Below, Q_H and Q_L denote the heat transfer rates between the system and the heat source or sink, respectively.)

