

**1**

# Signals and Signal Processing

# Introduction

- Examples of signals: Speech, music, picture, and video signals
- A signal is a function of independent variable, e.g., time, distance, position, temperature, pressure etc.
- Most signals are generated by natural means
- Signals may be generated synthetically or by computer simulation

# Signal Processing

- A signal carries information and the objective of signal processing is to extract the information carried by the signal, i.e.,

***Signal processing is concerned with the mathematical representation of the signal and the algorithmic operation carried out to extract the information present***

# Characterization of Signals

- One-dimensional (1-D) signal:
  - Function of a single independent variable, e.g., speech signal,  $s(t)$
- Two-dimensional (2-D) signal:
  - Two independent variables, e.g., image  $s(x,y)$
- Multidimensional signal:
  - Black and white video signal is a 3-D signal, two spatial variables and time, i.e.,  $v(x,y,t)$
  - Color video signal has three channels of 3-D signals (RGB), i.e.,  $u(x,y,t)=[r(x,y,t) \ g(x,y,t) \ b(x,y,t)]^T$

# Characterization of Signals

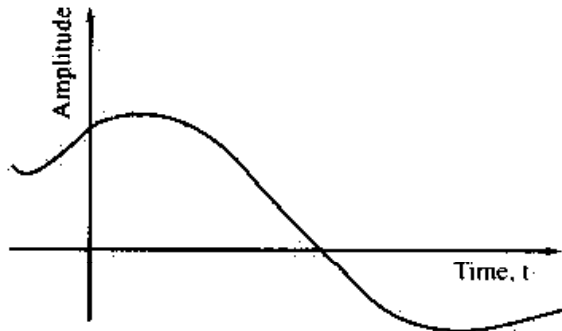

(a)

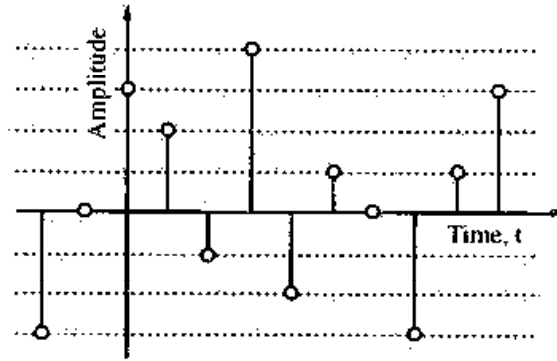

(b)

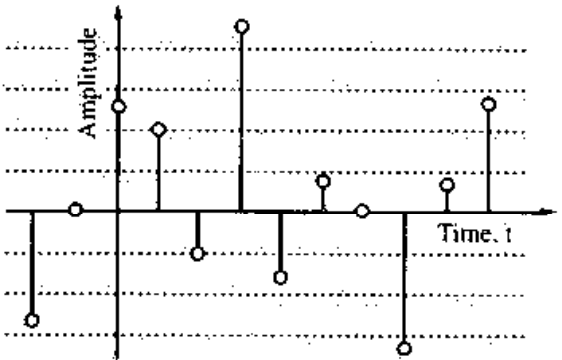

(c)

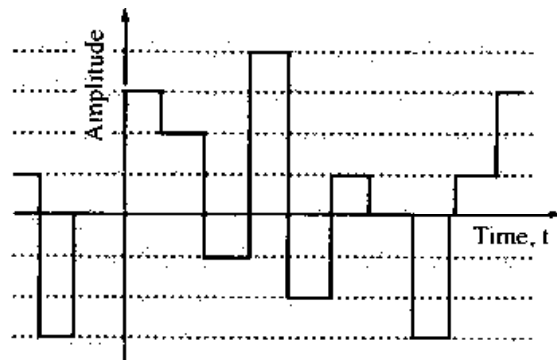

(d)

- (a) **Analog signal:**  
Continuous in both time and amplitude
- (b) **Digital signal:**  
Discrete in both time and amplitude
- (c) **Sampled-data signal:**  
Discrete-time and continuous-amplitude signal
- (d) **Quantized boxcar signal:**  
Continuous-time and discrete-amplitude signal

# Elementary Signal Processing Operations

- Scaling:  $y[n] = ax[n]$
- Delay:  $y[n] = x[n - n_0]$
- Addition:  $y[n] = ax_1[n] + bx_2[n] - cx_3[n]$
- Multiplication:  $y[n] = x_1[n]x_2[n]$

***Complex signal processing operations are implemented by combining two or more elementary operations***

# Filtering

- Filtering is used to pass certain frequency components in a signal through the system without any distortion and to block other frequency components
- Linear filtering is described in time-domain by the convolution operation

$$y[n] = \sum_{k=-\infty}^{\infty} h[n-k]x[k]$$

# Convolution

$$y[n] = \sum_{k=-\infty}^{\infty} x[k]h[n-k] = x[n] * h[n]$$

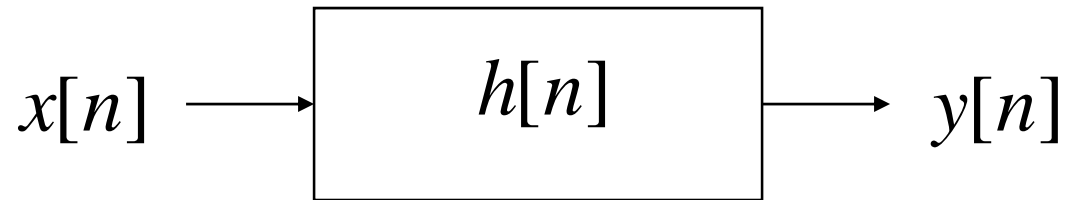

$$y(t) = \int_{-\infty}^{+\infty} x(\tau)h(t-\tau)d\tau = x(t) * h(t)$$



# Example: Filtering of a Signal

- Consider an input signal consisting of three sinusoidal components of frequencies 50 Hz, 110 Hz, and 210 Hz

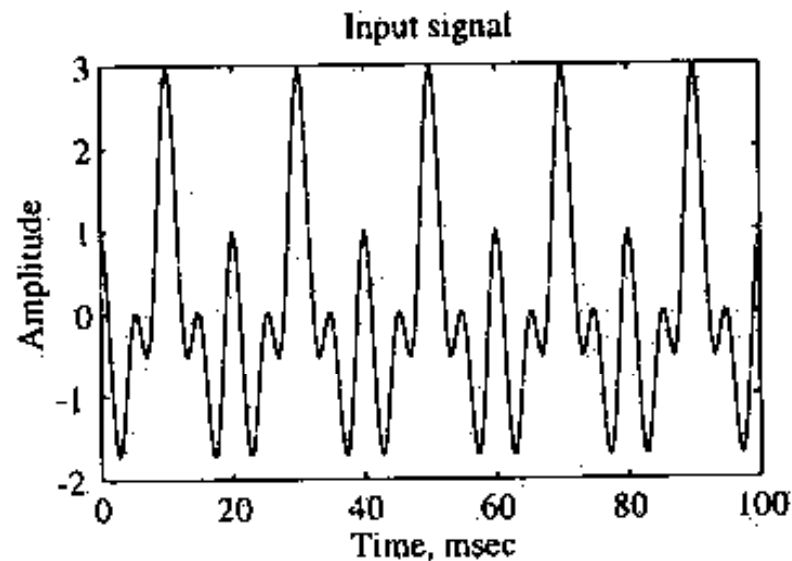

# Output of Different Filters

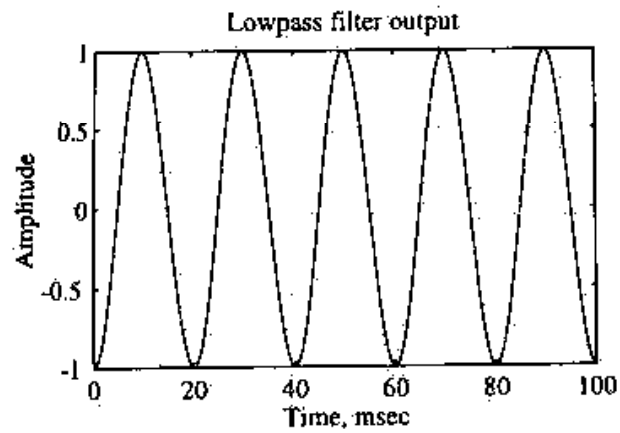

(b) Cutoff frequency at 80 Hz

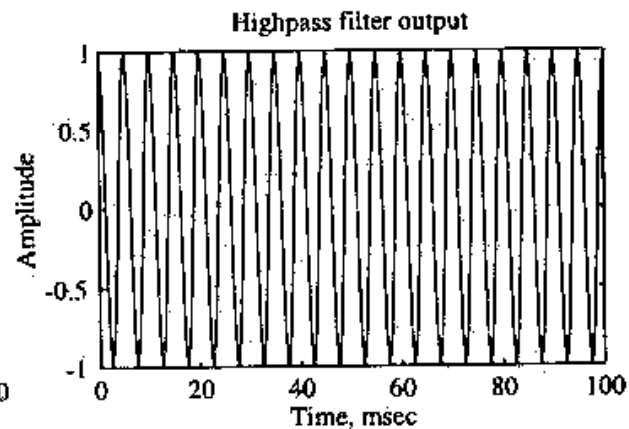

(c) Cutoff frequency at 150 Hz

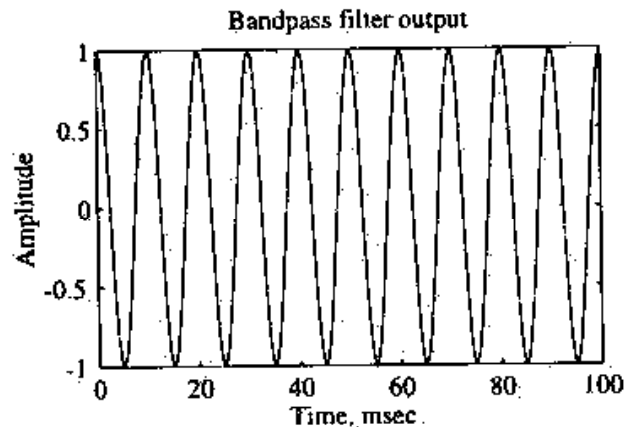

(d) Cutoff frequencies at 80 Hz and 150 Hz

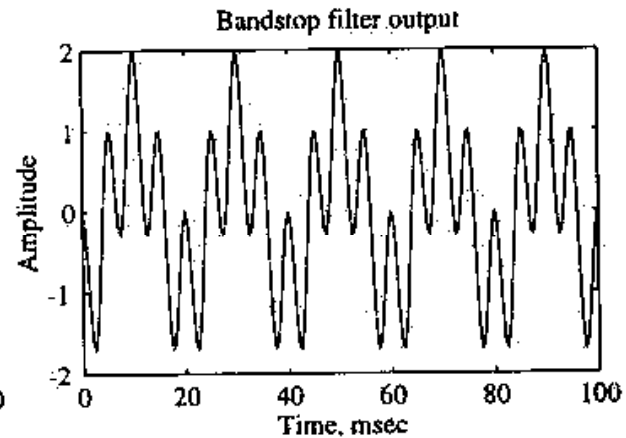

(d) Cutoff frequencies at 80 Hz and 150 Hz

# Modulation and Demodulation

- In ***amplitude modulation***, the amplitude of a high-frequency sinusoidal signal  $A\cos(\Omega_0 t)$ , called the ***carrier signal***, is varied by the low-frequency bandlimited signal  $x(t) = \cos(\Omega_1 t)$  (with  $\Omega_1 \ll \Omega_0$ ), called the ***modulating signal***, generating a high-frequency signal  $y(t)$ , called the ***modulated signal***, according to

$$\begin{aligned} y(t) &= Ax(t)\cos(\Omega_0 t) = A\cos(\Omega_1 t)\cos(\Omega_0 t) \\ &= \frac{A}{2}\cos((\Omega_0 + \Omega_1)t) + \frac{A}{2}\cos((\Omega_0 - \Omega_1)t) \end{aligned}$$

# Modulation and Demodulation

- The modulated signal  $y(t)$ , is composed of two sinusoidal signals at frequencies  $\Omega_0 + \Omega_1$  and  $\Omega_0 - \Omega_1$

$$Y(j\Omega) = \frac{A}{2} X(j(\Omega + \Omega_0)) + \frac{A}{2} X(j(\Omega - \Omega_0))$$

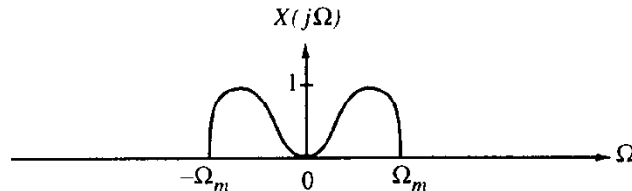

(a)

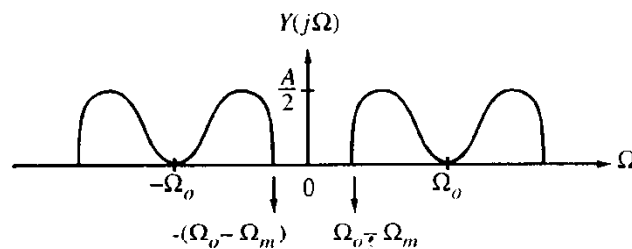

(b)

- Spectrum of the modulating signal  $x(t)$

- Spectrum of the modulated signal  $y(t)$

# Modulation and Demodulation

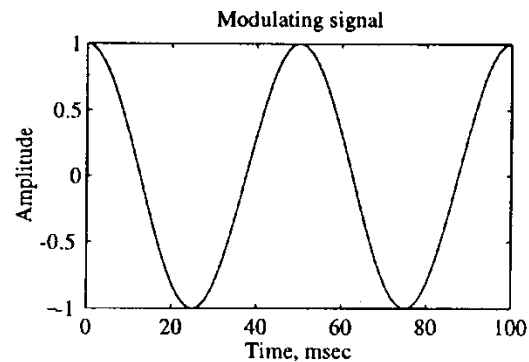
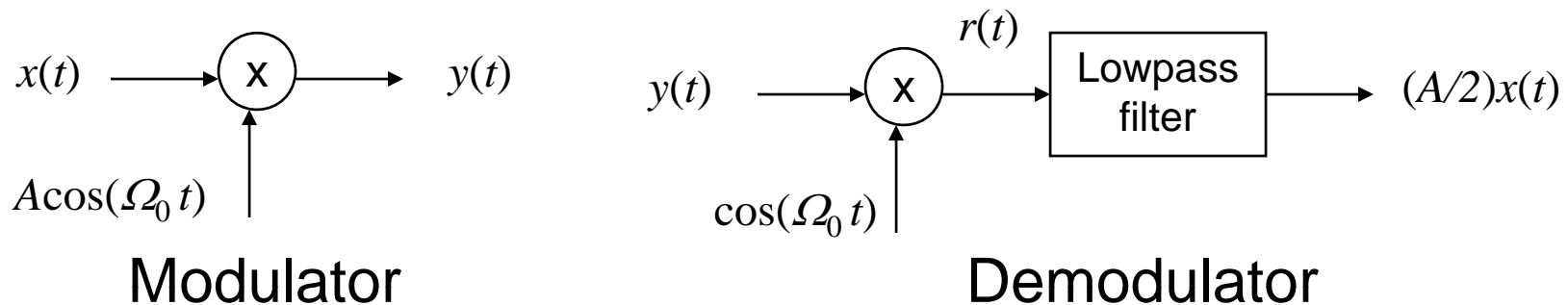

(a)

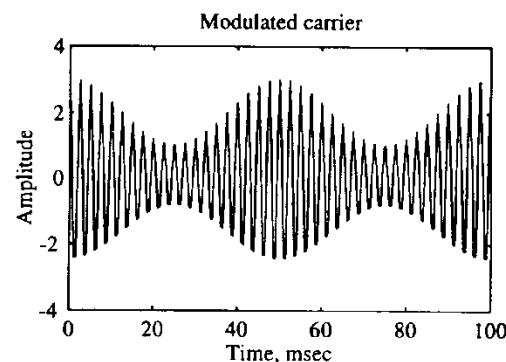

(b)

- The envelope of the modulated carrier is the waveform of the modulating signal

# Examples of Typical Signals

- Medical signals: ECG (electrocardiography) and EEG (Electroencephalogram) signals

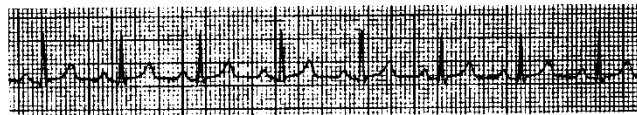

(a)

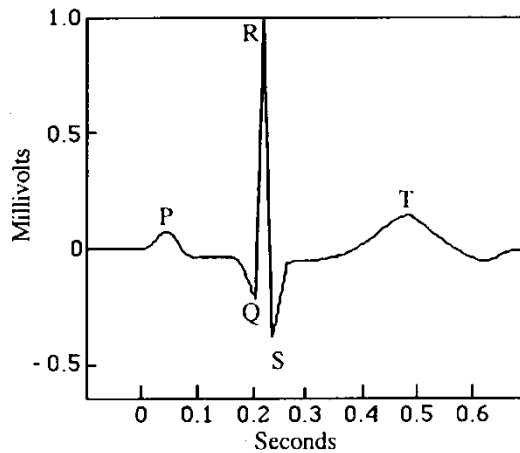

(b)

(a) A typical ECG trace and (b) one cycle of a ECG waveform

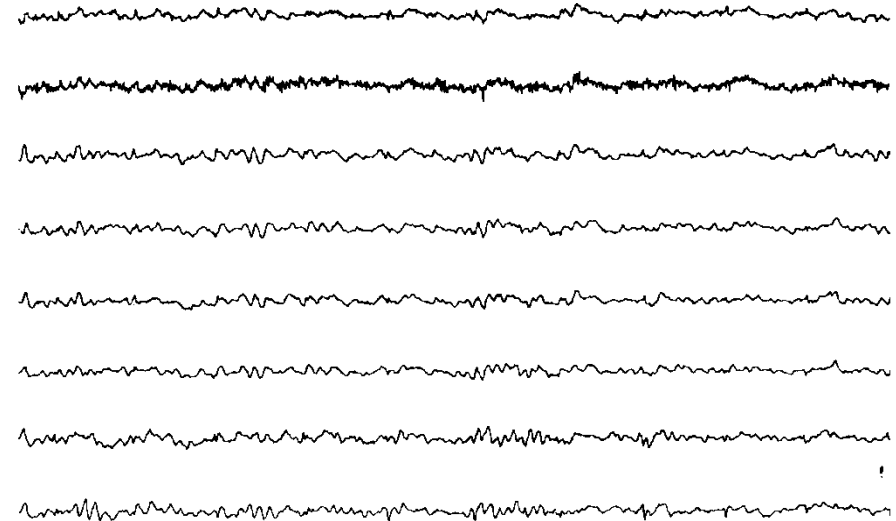
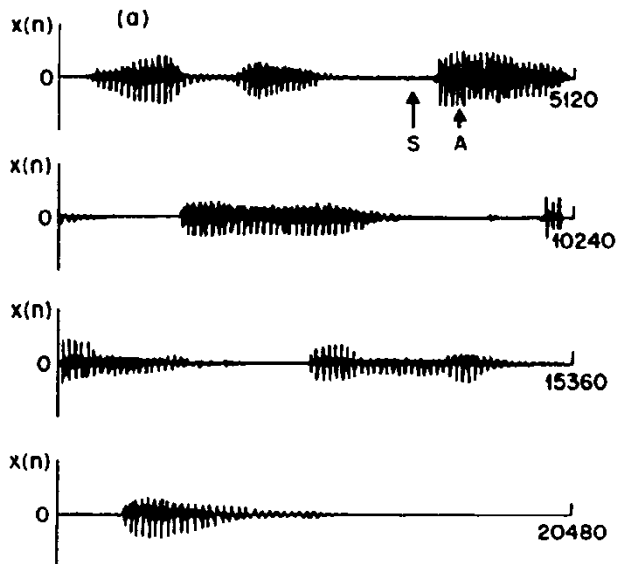

Figure 1.13 Multiple EEG signal traces.

# Example: Speech Waveform



(a) Sentence-length segment

(b) Magnified version of the voiced segment (letter A)

(c) Magnified version of the voiced segment (letter S)

# Signal Processing Applications

- Sound recording applications
  - Compressors and limiters
  - Expanders and noise gates
  - Equalizers and filters
  - Noise reduction systems
  - Delay and reverberation systems
- Telephone and dialing applications
- Electronic music synthesis
- Echo cancellation in telephone systems



# Telephone and Dialing Systems

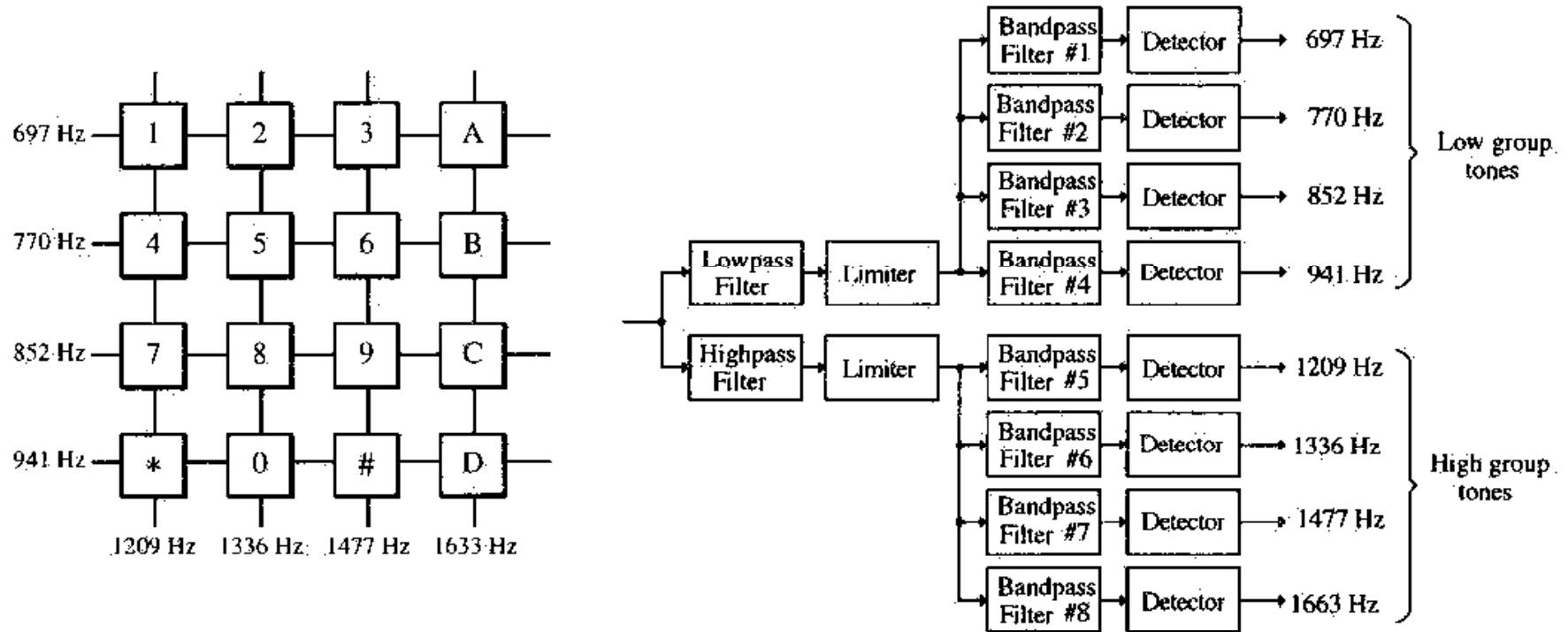

Pressing of each button generates a unique two-tone signal, e.g., pressing "4" corresponds to frequencies 770 Hz and 1209 Hz

- (1) The two tones are separated using lowpass and highpass filters
- (2) Then their frequencies are detected using bandpass filters

# Echo Cancellation

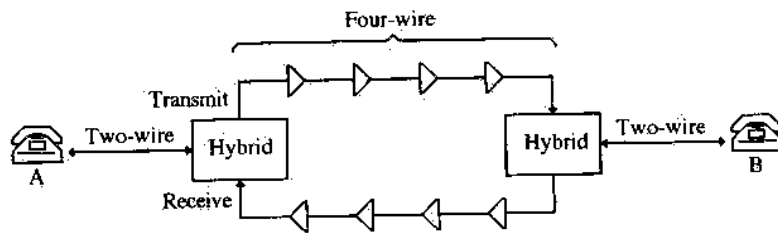

Figure 1.43 Basic 2/4-wire interconnection scheme.

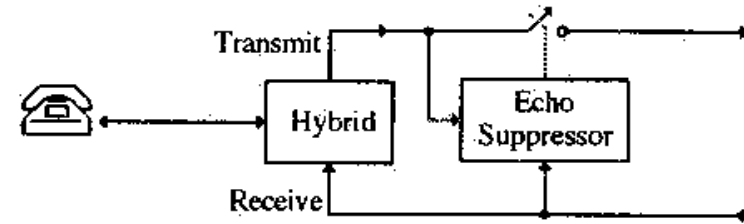

Figure 1.45 Echo suppression scheme.

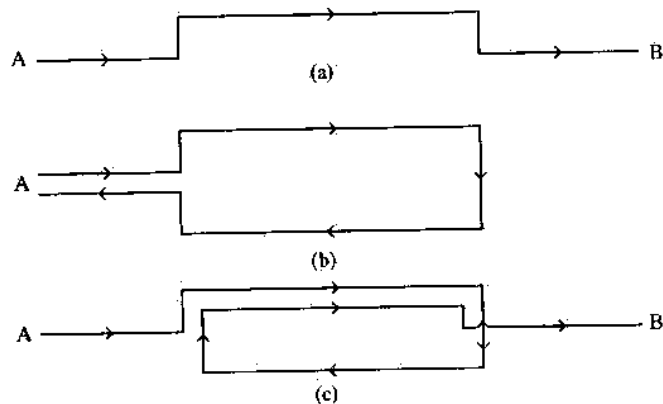

Figure 1.46 Echo cancellation scheme.

**Signal paths** in a telephone network:  
 (a) Transmission path, (b) echo path for the talker, and (c) echo path for the listener

**Echo suppression** detects the direction of conversation and blocks the opposite path;  
**Echo canceler** is an adaptive filter

# Why Digital Signal Processing ?

- 17<sup>th</sup> century: Finite difference methods, numerical integration methods, numerical interpolation
- 1950s: Simulation of analog signal processing methods
- 1960s: DSP started to be a field by itself due to an increase of computational power and applications, e.g., space research
- 1965: Invention of the FFT algorithm !

# System Block Diagram

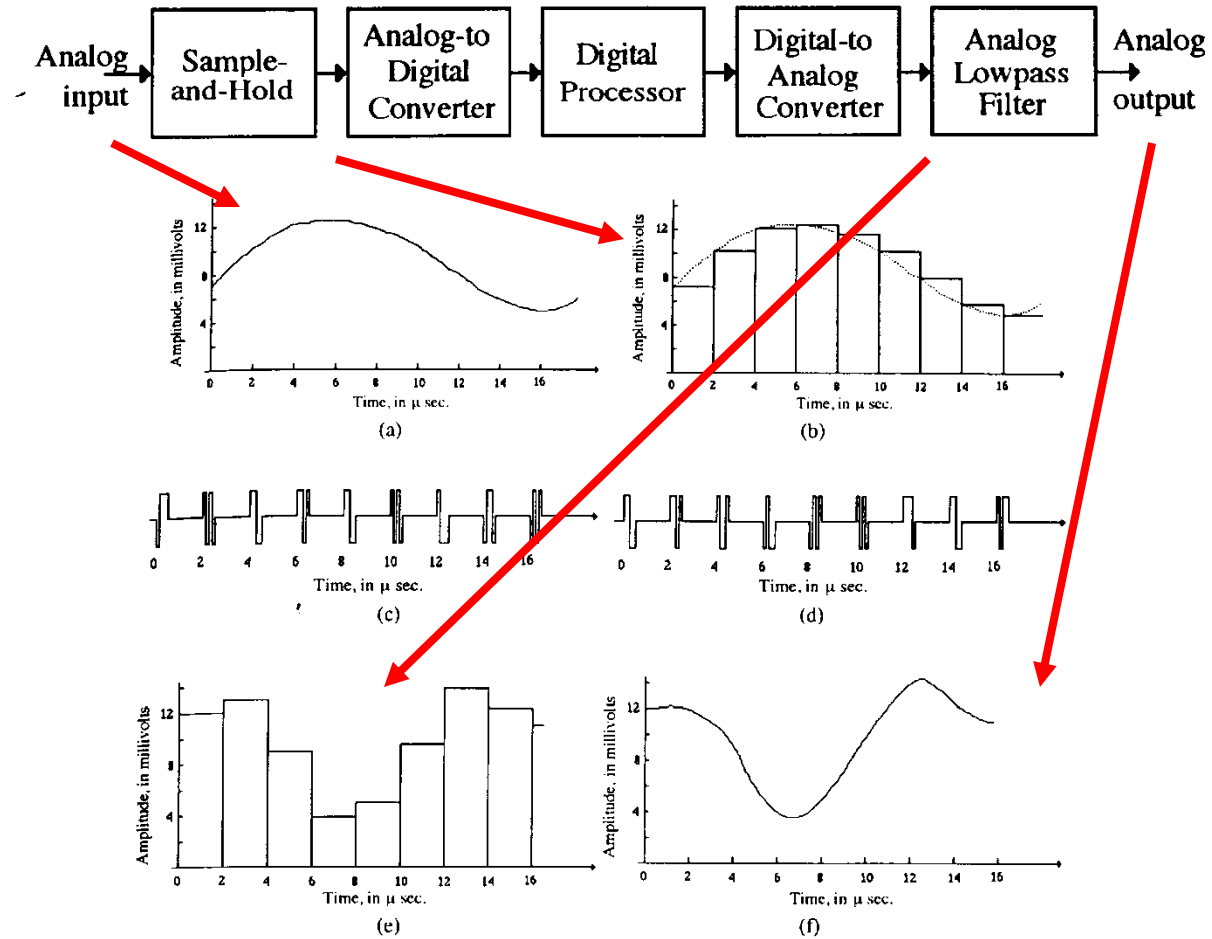

# Advantages of DSP

- Accuracy and stability
- Flexibility due to (re)programmability
- Implementation on VLSI and ASIC
- Functions that are not possible in analog signal processing
- Digitalization ...